

DUB™: Choose an MTB Bottom Bracket

Follow the chart to determine which bottom bracket works with your frame.

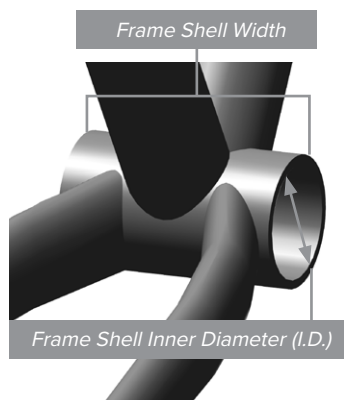

Is the frame shell threaded?

No

Yes

Frame Shell Width (mm)	Frame Shell I.D. (mm)	Crankset	Bottom Bracket Name	Part Number
73	42	MTB	DUB BB30 73 MTB	00.6418.017.000
		MTB Wide	DUB BB30 73 MTB Wide	00.6418.017.004
	46	MTB	DUB PF30 73 MTB	00.6418.018.000
		MTB Wide	DUB PF30 73 MTB Wide	00.6418.018.006
83	42	MTB Ai	■ DUB BB30 83 MTB Ai	00.6418.027.002
	46	MTB Ai	■ DUB PF30 83 MTB Ai	00.6418.028.003
89.5	41	MTB	DUB PF 89.5 MTB	00.6418.016.000
		MTB Wide	DUB PF 89.5 MTB Wide	00.6418.016.005
92	41	MTB	DUB PF 92 MTB	00.6418.016.000
		MTB Wide	DUB PF 92 MTB Wide	00.6418.016.005
		Super Boost +	DUB PF 92 SB+	00.6418.020.000
100	46	FAT	DUB PF30 100 FAT	00.6418.028.004
104.5	41	DH	DUB PF 104.5 DH	00.6418.016.002
107	41	DH	DUB PF 107 DH	00.6418.016.003
121	41	FAT	DUB PF 121 FAT	00.6418.016.001

Frame Shell Width (mm)	Frame Shell Type	Crankset	Bottom Bracket Name	Part Number
68	English Threaded	MTB	DUB BSA 68 MTB	00.6418.015.000
		MTB Wide	DUB BSA 68 MTB Wide	00.6418.015.005
73	English Threaded	MTB	DUB BSA 73 MTB	00.6418.015.000
		MTB Wide	DUB BSA 73 MTB Wide	00.6418.015.005
		Super Boost +	DUB BSA 73 SB+	00.6418.019.000
		MTB Ai	■ DUB BSA 73 MTB Ai	00.6418.031.001
73 with Chain Guide	English Threaded	MTB	DUB BSA 73 Guide MTB	00.6418.015.000
		MTB Wide	DUB BSA 73 Guide MTB Wide	00.6418.015.005
		Super Boost +	DUB BSA 73 Guide SB+	00.6418.021.000
83	English Threaded	DH	DUB BSA 83 DH	00.6418.015.002
		MTB Ai	■ DUB BSA 83 MTB Ai	00.6418.031.000
100	English Threaded	FAT	DUB BSA 100 FAT	00.6418.015.001

■ Cannondale® only

DUB™ MTB Crankset Bottom Bracket Spacers

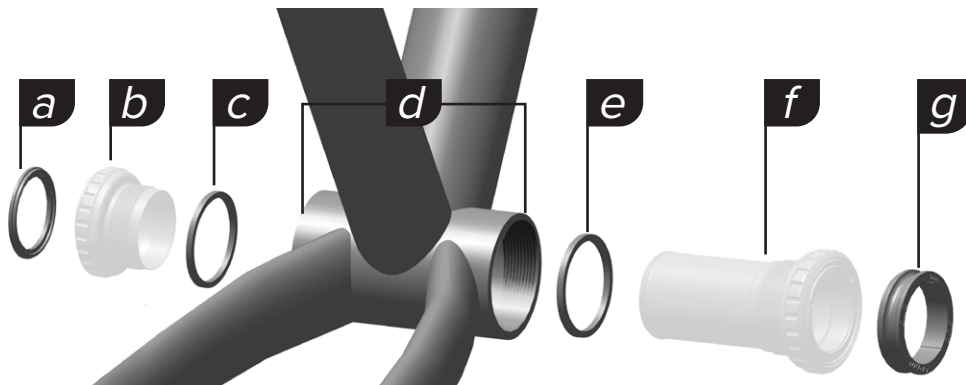

- a. Outer left, non-drive side spacer
- b. Left side cup
- c. Inner left, non-drive side spacer
- d. Frame shell width
- e. Inner right, drive side spacer
- f. Right side cup and center tube
- g. Outer right, drive side spacer

Frame Shell Interface and Width (mm)		Crankset	Outer Left Spacer (mm)	Inner Left Spacer (mm)	Inner Right Spacer (mm)	Outer Right Spacer (mm)
BSA	68	MTB	-	2.5	2.5	4.5
		MTB Wide	3	2.5	2.5	7.5
	73	MTB	-	-	-	4.5
		MTB Wide	3	-	-	7.5
		Super Boost +	4.5	-	-	9
	73 Ai	MTB Ai	2.5	2.5	-	10.5
	73 with Chain Guide	MTB	-	-	Chain Guide	2
		MTB Wide	3	-	Chain Guide	5
		Super Boost +	4.5	-	Chain Guide	6.5
	83	DH	-	2.5	2.5	4.5
	83 Ai	MTB Ai	-	-	-	5.5
	100	Fat	2	2.5	2.5	6
PressFit	89.5	MTB	-	-	-	4.5
		MTB Wide	3	-	-	7.5
	92	MTB	-	-	-	2
		Super Boost +	4.5	-	-	6.5
		MTB Wide	3	-	-	5
	104.5	DH	-	-	-	4.5
	107	DH	-	-	-	2
121	Fat	2	-	-	6	
PressFit 30	73	MTB	-	-	-	4.5
		MTB Wide	3	-	-	7.5
	83	DH	3	-	-	6.5
	83 Ai	MTB Ai	-	-	-	5.5
	100	Fat	4.5	-	-	8.5
BB30	73	MTB	-	-	-	4.5
		MTB Wide	3	-	-	7.5
	83 Ai	MTB Ai	-	-	-	5.5